

CLIPSAL[®]
LIVING ELECTRICAL

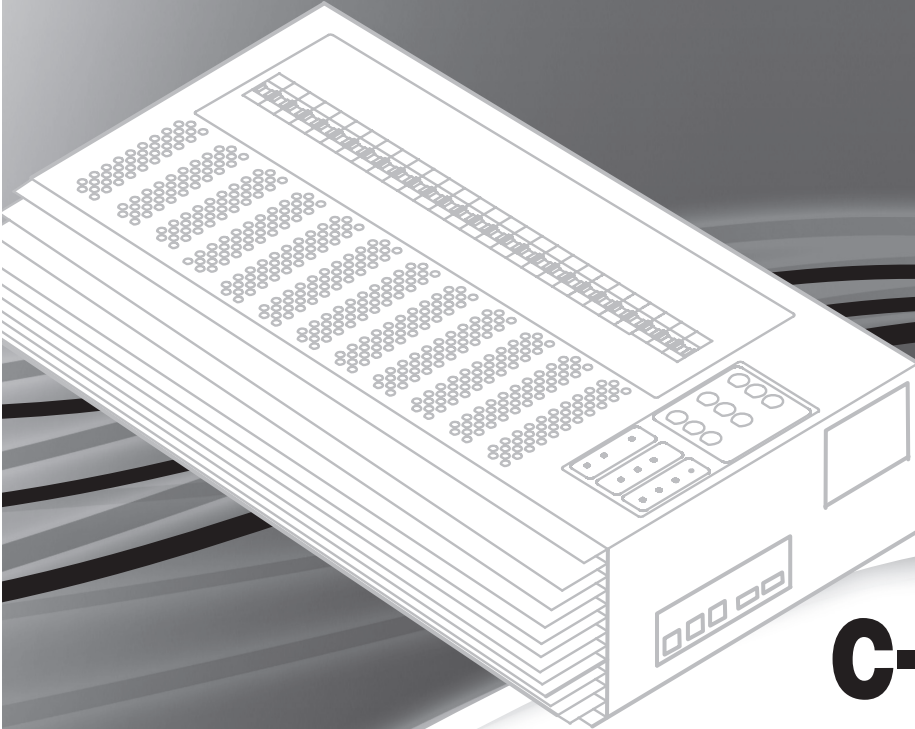

C-Bus[®]
Professional Series
Dimmer

L51xxDxxLP

L51xxDxxTP

Series



Installation Instructions

REGISTERED DESIGN • REGISTERED PATENT

Clipsal is a registered trademark of Clipsal Australia Pty Ltd ABN 27 007 873 529.

C-Bus is a registered trademark of Clipsal Australia Pty Ltd.

Megger is a registered trademark of AVO International (formerly the Biddle Co.), but the term is widely used for all similar tests regardless of manufacturer.

© Copyright Clipsal Australia Pty Ltd 2008. All rights reserved. This material is copyright under Australian and international laws. Except as permitted under the relevant law, no part of this work may be reproduced by any process without prior written permission of and acknowledgement to Clipsal Australia Pty Ltd.

The information in this manual is provided in good faith. Whilst Clipsal Australia Pty Ltd (CAPL) has endeavoured to ensure the relevance and accuracy of the information, it assumes no responsibility for any loss incurred as a result of its use. CAPL does not warrant that the information is fit for any particular purpose, nor does it endorse its use in applications that are critical to the health or life of any human being. CAPL reserves the right to update the information at any time without notice.

V1.0 May 2008

CONTENTS

1.0	Product Range	5
1.1	Leading Edge Dimmer Units	6
1.2	Trailing Edge Dimmer Units	7
2.0	General Description	8
3.0	Controls and Indicators	10
3.1	Phase Indicator LEDs	10
3.2	C-Bus Unit and Status Indicator LEDs	10
3.3	Channel Toggle and Indicator Buttons	11
3.4	Priority of Control Modes	11
4.0	Features and Capabilities	12
5.0	Getting Started	13
5.1	Product Safety	13
5.2	Installation Requirements	14
5.3	What You Need to Install the Unit	14
5.4	Compatible Loads	15
6.0	Installation Steps	16
6.1	Mounting Considerations	17
6.2	Wiring Instructions	18
6.3	C-Bus Network Connection	19
6.4	Remote On/Off and Remote Override	20
7.0	Module Removal and Installation	23
7.1	Removing a Channel Card	23
7.2	Installing a Channel Card	24
7.3	Replacing an MCB	24
8.0	C-Bus Programming	25
8.1	Network Burden	25
8.2	Network Clock	25
9.0	Troubleshooting	26

10.0	Definitions and Acronyms	27
11.0	Electrical Specifications	28
	12-Channel Models: L5112D20LP / L5112D16LP L5112D10LP / L5112D10TP	28
	12-Channel Models: L5112D5LP / L5112D3LP L5112D5TP / L5112D3TP	29
	6-Channel Models: L5106D20LP / L5106D10LP L5106D20TP / L5106D16TP / L5106D10TP	30
	6-Channel Models: L5106D5LP / L5106D3LP L5106D5TP / L5106D3TP	31
	3-Channel Models: L5103D20LP / L5103D10LP / L5103D5LP L5103D20TP / L5103D10TP / L5103D5TP	32
12.0	Environmental and Mechanical Specifications	33
	12.1 Environmental Specifications (all models)	33
	12.2 Leading Edge Mechanical Specifications	34
	12.3 Trailing Edge Mechanical Specifications	34
13.0	Standards Complied	35
14.0	Two-Year Warranty	37

1.0 Product Range

The Professional Series Dimmers are available as leading edge or trailing edge units. You can specify 3, 6, or 12 dimmer channels that operate at a specified current rating. Optional variants with Residual Current Devices (RCDs/RCCBs) and 3-phase MCBs might be required for some applications. For the latest information, contact your Clipsal representative.

The catalogue number represents the configuration of your dimmer unit. The definitions of the fields in the number are shown below.

	Product identifier	Number of channels	Dimmer unit	Current per channel	Leading edge	Professional series	No. of RCDs/RCCBs	No. of 3-phase MCBs
L51	xx	D	xx	L	P	Rxx	xM	
L51	12	D	20	L	P	12	3	
	06		16			6		
	03		10			3		
			5			1		
			3					

	Product identifier	Number of channels	Dimmer unit	Current per channel	Trailing edge	Professional series	No. of RCDs/RCCBs	No. of 3-phase MCBs
L51	xx	D	xx	T	P	Rxx	xM	
L51	12	D	20	T	P	6	3	
	06		16			3		
	03		10			1		
			5					
			3					

1.1 Leading Edge Dimmer Units

Table 1 shows the nominal current per channel and supply phases and maximum load for leading edge models.

Do not exceed the maximum load allowed for the dimmer unit.

Catalogue No.	Channels	Current per Channel	Supply phases	Maximum unit load
L5112D20LP	12	20A	3 ϕ	180A
L5112D16LP	12	16A	3 ϕ	180A
L5112D10LP	12	10A	3 ϕ	120A
L5112D5LP	12	5A	3 ϕ	60A
L5112D3LP	12	3A	1 ϕ /2 ϕ	36A
L5106D20LP	6	20A	3 ϕ	120A
L5106D10LP	6	10A	3 ϕ	60A
L5106D5LP	6	5A	1 ϕ /3 ϕ	30A
L5106D3LP	6	3A	1 ϕ	18A
L5103D20LP	3	20A	3 ϕ	60A
L5103D10LP	3	10A	1 ϕ /3 ϕ	30A
L5103D5LP	3	5A	1 ϕ	15A

Table 1. Leading Edge Channel phase and current characteristics

1.2 Trailing Edge Dimmer Units

Table 2 shows the nominal current per channel and supply phases and maximum load for trailing edge models.

Do not exceed the maximum load allowed for the dimmer unit.

Catalogue No.	Channels	Current per channel	Supply phases	Maximum unit load
L5112D10TP	12	10A	3 ϕ	120A
L5112D5TP	12	5A	3 ϕ	60A
L5112D3TP	12	3A	1 ϕ /2 ϕ	36A
L5106D20TP	6	20A	3 ϕ	120A
L5106D16TP	6	16A	3 ϕ	120A
L5106D10TP	6	10A	3 ϕ	60A
L5106D5TP	6	5A	1 ϕ /3 ϕ	30A
L5106D3TP	6	3A	1 ϕ	18A
L5103D20TP	3	20A	3 ϕ	60A
L5103D10TP	3	10A	1 ϕ /3 ϕ	30A
L5103D5TP	3	5A	1 ϕ	15A

Table 2. Trailing Edge Channel phase and current characteristics

2.0 General Description

The Professional Dimmer series is a range of high power, multi-channel C-Bus dimmer units. These wall-mounted units are available with 3, 6 or 12 dimmer channels with leading edge or trailing edge phase control. Refer to the table below.

Channel Card Type	Load Current	Output Stage Technology
LE (Leading Edge)	3A / 5A	Single Triac with Toroidal Choke
LE	10A / 20A	Dual SCRs with Toroidal Choke
TE (Trailing Edge)	3A - 20A	Dual MOSFETs

Each channel has an overload circuit breaker (MCB), thermal protection, and a power connection for external emergency lighting systems. When customer requirements change, dimmer channel cards can be upgraded in the field. Contact the Clipsal sales organisation for details and product availability.

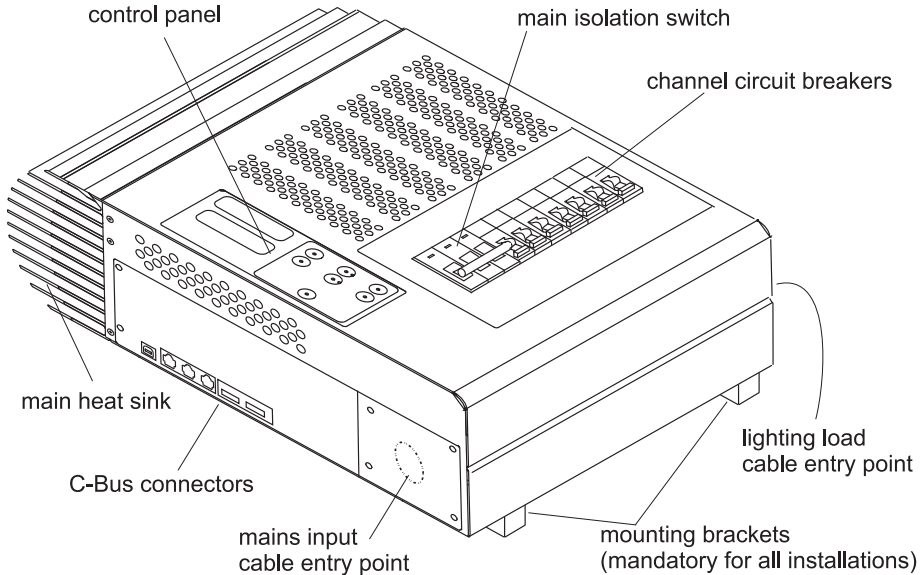

Figure 1. Professional Dimmer unit (6 channel dimmer shown)

The main isolation switch disconnects all internal circuits from building power. In addition, each dimmer channel has a circuit breaker. Each channel also has a local toggle switch on the front control panel. The soft power on/off feature helps protect lamp filaments.

The Professional Dimmer is programmed using C-Bus Toolkit software and has 'learn' capability. The dimmers have software-enabled C-Bus clocks and burden. After programming the dimmer channels, they will return to their previously set lighting levels, in the event that AC power is lost and restored.

When connected to mains power, the dimmer unit does not sink current from the C-Bus network. The bottom panel has three RJ45 C-Bus connectors wired in parallel and a 4-pin C-Bus connector wired in parallel with them. A four-pin connector is provided for optional, independent remote on/off operation.

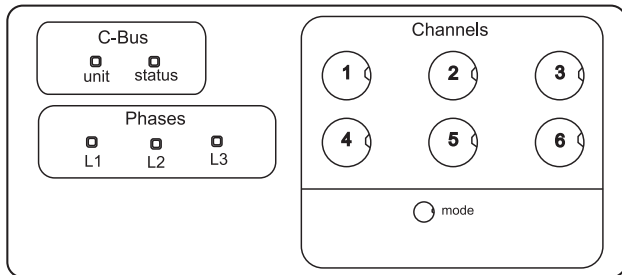

Figure 2. Front Control Panel

Each dimmer channel card has an override switch for testing the connected lighting load at full power or isolating the electronics for Megger testing.

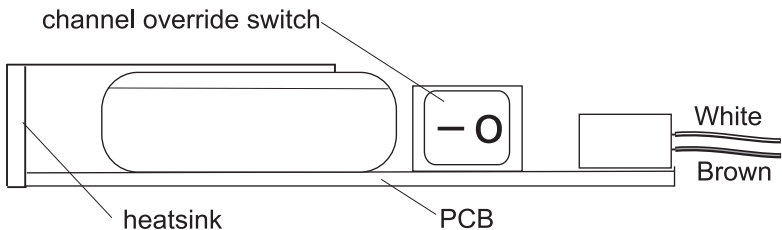

Figure 3. Channel override switch location

3.0 Controls and Indicators

The C-Bus indicators, Phases indicators and channel buttons are located on the front panel. The channel buttons provide local on/off switching, mode and fault status. To decode the indicator LEDs, refer to the chart located inside the front access cover.

3.1 Phases indicator LEDs

The ‘Phases’ indicators provide a visual check on the presence or absence of input voltage phases inside the dimmer unit. The main input isolations switch must be on for the indicators to work. Be aware that dangerous voltages might be present inside the unit even when the indicators are not illuminated.

3.2 C-Bus Unit and Status Indicator LEDs

The ‘unit’ indicator shows the status of the C-Bus inside the dimmer. The unit indicator modes are shown in Table 3.

Indicator mode	Meaning
On	Normal operation
Flashing	Unit is in override mode
Off	No power to unit

Table 3. C-Bus Unit Indicator LED modes

The ‘status’ indicator shows the status of the C-Bus network. If sufficient network voltage and a valid C-Bus clock signal are present, the indicator illuminates (as a continuous green light).

Indicator mode	Meaning
On	The power is on and the network is functional
Flashing	The network voltage is marginal; above 15 V, but less than 20 V
Off	No C-Bus clock is present, mains power is not connected, or network voltage is below 15 V

Table 4. C-Bus Status Indicator LED modes

3.3 Channel Toggle and indicator Buttons

The channel buttons control the local override function. The buttons allow you to toggle each channel on and off. Each button LED illuminates when its respective channel is in the ON state. The local override option can be disabled using the C-Bus Toolkit software.

When disconnected from a C-Bus network, the dimmer can function as a stand-alone unit, provided the channels are programmed, using the C-Bus Toolkit software.

Depending on how they are pressed, the buttons perform different functions. The double quick-press and long press operations only apply when the unit/channel is in local override mode.

Operation	Function
Quick-press	A single quick-press toggles the state of a channel
Double quick-press	Two quick-presses in quick succession returns the channel to the C-Bus network level
Long press	Pressing any of the buttons for 1 second or more returns all channels to the C-Bus network level

Table 5. Channel toggle button functions

3.4 Priority of Control Modes

Because a channel may be controlled by various means, there is a priority of control modes. Table 6 provides the priority information.

Mode	Priority	Function
Current overload	1 (highest)	channel off (MCB trips)
Electronic cutout	2	TE channels off (MCB on)
Thermal shutdown	3	channel power ramps down
Remote off (option)	3	all channels off
Remote on (option)	4	all channels on
Channel buttons and C-Bus Toolkit software	5	Toggle the channel and provide programming control

Table 6. Priority of Control Modes

4.0 Features and Capabilities

- In the event of an over-temperature condition, for example, one caused by excessive load current being drawn, the dimmer channel reduces the output power as long as the condition exists.
- Soft load turn-on helps protect lamp filaments.
- The dimmer incorporates voltage compensation (over a significant part of the dimming range) to minimise load brightness variation if the AC supply voltage drifts.
- The dimmer incorporates filtering to reduce load brightness fluctuations typically associated with the presence of AC supply voltage signalling.
- In the event of AC supply voltage failure, current dimming output levels are stored. When power recovers, the dimming levels automatically return to previous values, or preset values.
- At the C-Bus Group Address level, output load power variation follows the input control in a linear fashion.
- The C-Bus Toolkit software reports the network voltage.
- The dimmer unit has software-selectable C-Bus network burden and network clock generator for standalone configurations (provided that the channels are programmed with preset levels).
- Dimmer channel cards are upgradeable in the field. For example, a 10A LE card can be upgraded to 20A LE. Contact your local Clipsal sales office for information.
- The dimmer can be supplied by Clipsal with preconfigured RCDs and 3-phase MCBs, as needed.

5.0 Getting Started

5.1 Product Safety

- Only qualified personnel may install and maintain the dimmer units. The installation must meet all local safety requirements.
- The Professional Series Dimmers are for indoor use only. Never allow liquids to spill or drip on the top of the unit.
- Follow all cautions and safety instructions on the packaging materials and on the unit.
- Units weigh from 10kgs to 40kgs. Make certain that the mounting fixtures are secure before attaching the unit, and get assistance from another person when lifting.
- During normal operation, the heat sink can be hot to the touch.
- Hazardous voltage is present at the dimmer channel outputs when mains power is connected. Turn off the main isolation switch and padlock it before accessing the lighting circuits.
- Do not block the ventilation holes at the top and bottom of the unit. Do not allow debris or dust to enter the unit.
- Avoid electrical shock. Do not service the unit if it is wet. Do not stand on a wet surface when servicing the unit.
- For protection against fire and equipment damage, when upgrading a channel card, you must replace the associated MCB with one of the correct type and current rating. Refer to Module Installation and Replacement.
- Do not connect more than three MCBs downstream from a single RCD.
- All connections must be tight to avoid risk of fire or damage to equipment. Connections might loosen during shipment.
- Do not exceed current ratings per channel or per unit. Refer to Electrical Specifications.

5.2 Installation Requirements

- The dimmer unit must be connected to phases equipped with a protective device that has a short circuit withstand current rating of 6 kA.
- Use of the supplied mounting brackets is mandatory. Refer to Mounting Considerations.
- Airflow around the main heatsink and the ventilation holes must not be restricted. If an enclosure is used, it must provide adequate ventilation.
- Connect only compatible load types to the dimmer.
- Using non C-Bus software voids the warranty.
- Avoid wiring dimmer channels in parallel.
- Avoid shorting dimmer channel outputs to neutral or earth.
- Isolate the dimmer channel cards using the circuit breakers before Megger® testing the load wiring.
- Clipsal does not recommend soldered connections for mains, output or C-Bus wiring.
- Clipsal recommends the use of external protection against power surges.

5.3 What you need to install the unit

When installing the dimmer unit on the wall, you need the following:

- Mounting bracket template that is shipped with the unit.
- 2 Mounting brackets, shipped with the unit.
- 4 Mounting screws or anchors (not supplied), appropriate for wall material and thickness.

Optional Items that might be helpful:

- Merlin Gerin padlocking device for the main input isolation switch; catalogue number 26970
- Clipsal 970 Series Surge suppression device
- Clipsal C-Bus Network Analyser tool (5100NA)
- Megger® test equipment

5.4 Compatible Loads

The leading edge dimmer channels can supply power to a wide range of load types. Refer to Wiring Instructions for diagrams and best practices. Dimmer channel loading is limited by two factors:

- Never exceed the maximum load on any input phase. Refer to Electrical Specifications.
- Never exceed the rated value of the channel overload MCB.

Incandescent and 240V halogen lamps

The minimum load requirement can be found in Electrical Specifications. When using several channels, distribute the load as evenly as possible among the channels.

Electronic transformer

Be sure to use transformers that are compatible with leading edge phase-control dimmers. Most electronic transformers are compatible with this dimmer type. Check with the manufacturer of the transformer.

Neon lighting with iron core transformers

Clipsal recommends using an appropriately rated circuit breaker between the dimmer unit and each iron-core transformer. The dimmer channel overload MCB might have too high a current rating to protect an individual transformer.

Low voltage lighting with iron core transformers

There are no special wiring considerations.

Note: Only iron core transformers compatible with electronic switches may be used to ensure compliance to IEC 60669-2-1.

Motor speed control

The motor running current total and all other connected lighting loads must not exceed the channel card load rating.

6.0 Installation Steps

Install the dimmer unit using these steps to minimise the risk of personal injury or damage to the dimmer unit or lighting fixtures.

1. Check the unit for obvious physical damage before installation.
2. Choose a wall location for the dimmer where the unit will not interfere with normal business operations. Provide for adequate ventilation. See Mounting Considerations.
3. Use the supplied template. Accurately drill the mounting holes. Install the mounting brackets securely to the wall.
4. Place the dimmer unit on the mounting brackets. Check that the unit is securely fastened to the wall.
5. Measure the hole size needed for cable entry. Drill holes in the cover plates so that there are no gaps larger than 10mm around the cables. There must be no sharp edges around the cable entry holes. Insulated conductors shall not rest against bare live parts at a different potential and shall be adequately supported.
6. Install the cable entry covers.
7. Label all wire ends before inserting them into the dimmer enclosure. Connect the lighting load wiring, do not exceed maximum rated load current per channel. The dimmer unit is compatible with copper and aluminium conductors.
8. Connections can loosen during shipping. Make sure that all internal circuit breaker and terminal connections are tight.
9. Route the C-Bus network cables away from mains power conductors to comply with all local wiring regulations.
10. Isolate the unit from mains power before performing Megger® testing.
11. Double check all wiring connections before applying mains power to the unit.

6.1 Mounting Considerations

You must use the supplied mounting brackets. The mounting bracket hole size is 10 mm. Use the installation template to accurately drill the four required holes. Select a fastener type that will hold the weight of the dimmer unit.

To ensure reliable operation, provide adequate ventilation for the unit. When installing multiple dimmer units, the minimum clearance between units must be 100 mm (3.9 inches) in both directions. See Figure 4.

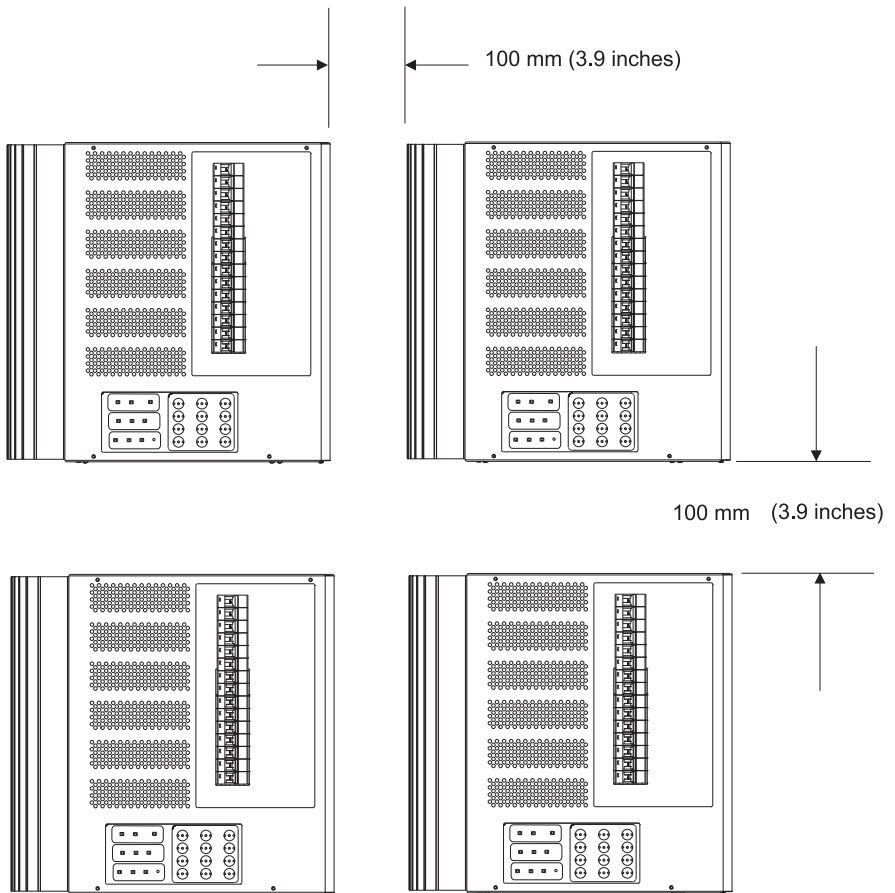

Figure 4. Mounting clearance for multiple units

6.2 Wiring Instructions

Mains input power enters the enclosure and is connected to the main isolation switch terminals. The bus bar distributes power to the channel MCBs. Neutral and earth connections branch out from main terminal blocks. Refer to Figure 5.

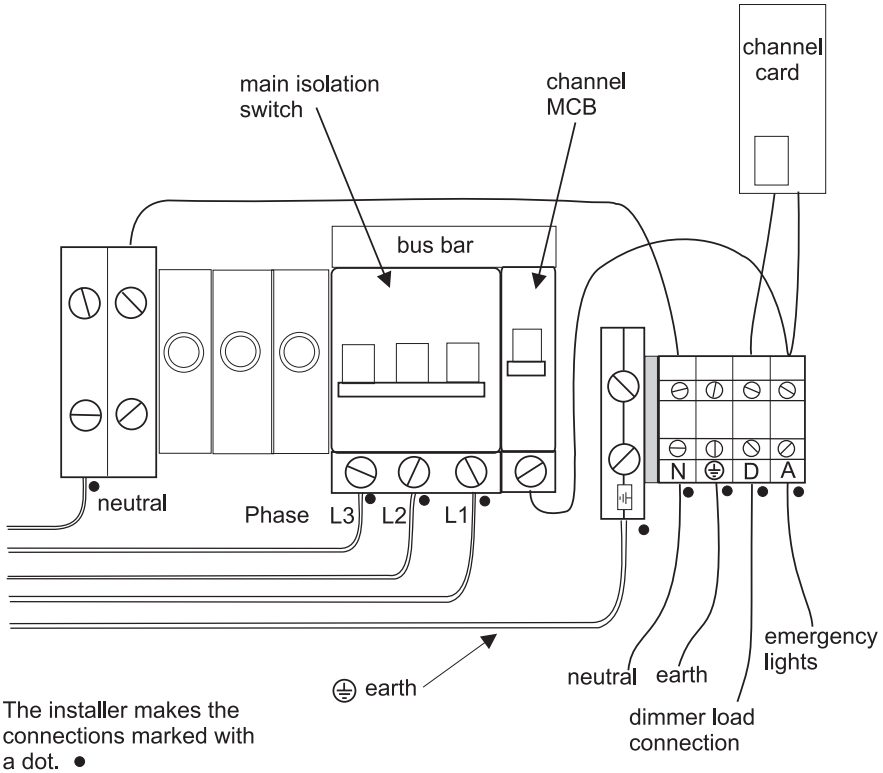

Figure 5. Basic wiring diagram for installation

6.3 C-Bus Network Connection

Connection to the C-Bus network is made using the RJ45 sockets or the C-Bus four-pin connector (all wired in parallel). Use Cat-5 Unshielded Twisted Pair (UTP) C-Bus cable, and an appropriately wired RJ45 plug or supplied 4-pin female plug. Pinouts are provided in Figure 6.

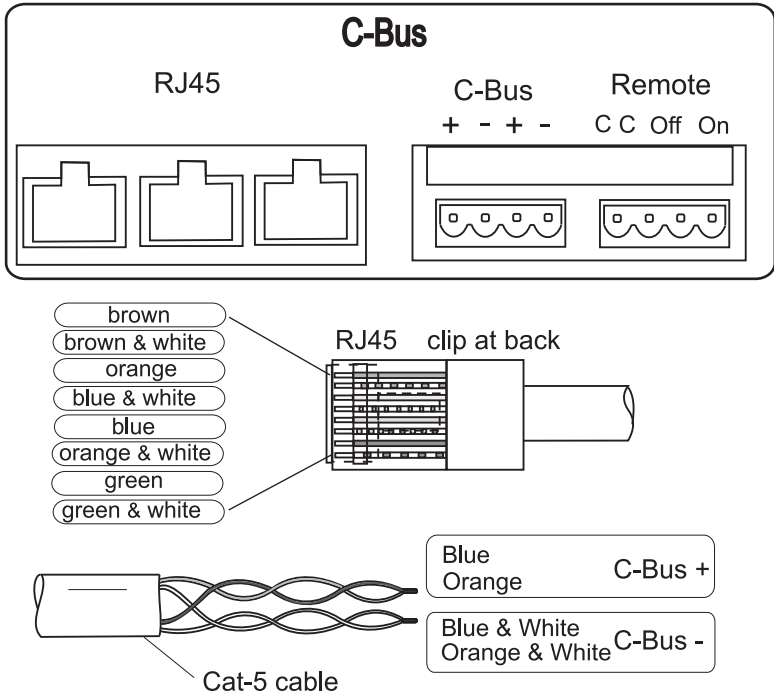

Figure 6. C-Bus wiring connections

The Clipsal catalogue number for the C-Bus Cat-5 UTP cable is 5005C305B.

6.4 Remote On/Off and Remote Override (options)

Remote On/Off

Remote On/Off connections are optional. If you intend to use this feature, connect the green/green&white and brown/brown&white pairs across the network during installation. Otherwise tie back the unused wire pairs.

On the C-Bus network, when one of the remote inputs is enabled (active low referenced to C-Bus negative), all dimmer channels are set to either ON or OFF. In the event that the Remote On and Remote Off functions are activated simultaneously, Remote Off has priority. Refer to Table 6.

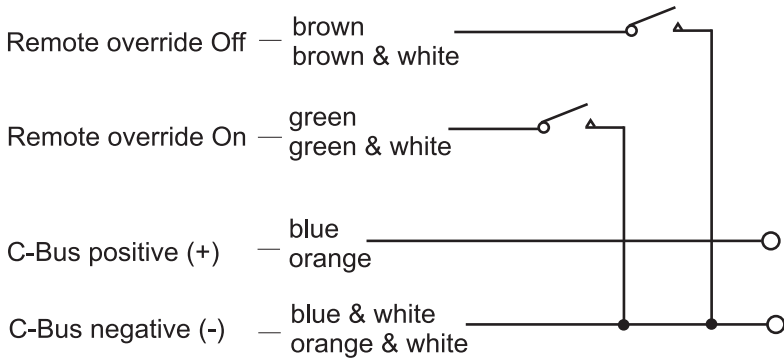

Figure 7. C-Bus Network Remote On/Off wiring diagram

Remote Override

The Remote Override on the dimmer unit is capable of working independently of the C-Bus network. There are several methods of wiring, depending on how the Remote Override is to be used.

Note: The REMOTE 'C' terminals are connected together. The extra 'C' connection is provided to connect REMOTE 'C' to C-Bus '- '.

Figure 8 shows the wiring of a dimmer unit where the Remote Override circuit is connected to the C-Bus network. In this configuration, the C-Bus network controls the Remote On/Off function of the dimmer unit.

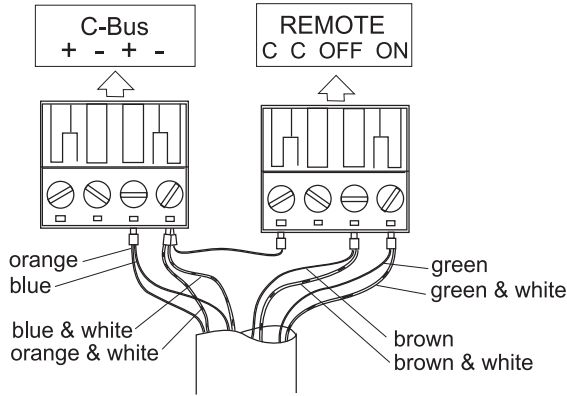

Figure 8. Standard C-Bus connection with Remote Override connected to C-Bus

The Remote Override for the dimmer unit can function independently of the C-Bus network. Figure 9 shows the wiring for independent unit operation. In this alternate Remote Override mode, the Remote terminals are NOT connected to the C-Bus cable.

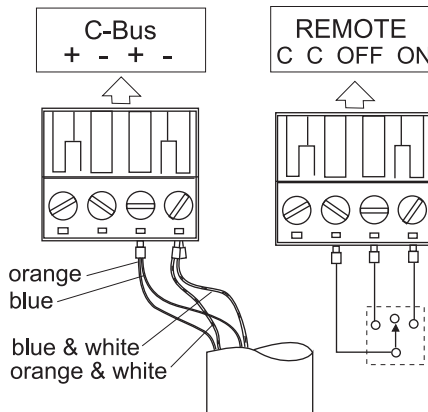

Figure 9. Dimmer unit Remote Override independent of the C-Bus network

C-Bus Power Requirements

C-Bus Professional Series Dimmers sink current from the C-Bus network when mains power is not connected. Dimmer units do not need a mains connection during programming.

Parameter	Description
C-Bus supply voltage	20 V to 36 V DC
Maximum units per network	100
Unit input current	0 mA (mains connected) 18 mA (no mains connected)
Unit output current (onto C-Bus)	0 mA
Connection type	RJ45 (3 locations) 4-pin female (wired in parallel with RJ45)
Network clock	Software selectable
Network burden	Software selectable (unit address 001 only)

The C-Bus Toolkit software provides a summary of a C-Bus network project. This can be helpful in determining the power supply requirements of a particular network.

7.0 Module Removal and Installation

Replacing a channel card should only be attempted under the guidance of Clipsal technical support personnel.

7.1 Removing a Channel Card

Before starting, make certain that you have a screwdriver and materials to label the card after removing it from the unit.

1. Identify the channel card to be replaced before powering off the unit.
2. Power off the unit and disconnect mains power using the main isolation switch. Do not rely on the 'Phases' indicators on the front display panel to tell you if power is present inside the unit.
3. Open the front cover panel and disconnect the earth wire connection from the door to the chassis.
4. Disconnect the power cable from the channel card to be removed. Slide the connector from the terminals. Do not pull on the brown and white wires.
5. Remove the machine screw that fastens the channel card heat sink to the main heat sink.
6. Pull the channel card out of the card connector. You can use a screwdriver to lever out the channel card.
7. When it is free from the unit, label the card and put it in a safe place. If you are returning a channel card to Clipsal, label it and pack it properly. Be sure to label the card with the following information:

Dimmer unit catalogue and serial numbers
Channel card location and serial number
Date the part was removed
Reason for removal from the unit.

7.2 Installing a Channel Card

1. Remove the new channel card from the package. Save the package to return the original card to Clipsal.
2. Examine the card carefully for any damage from shipping.
3. Connect the channel card power cable to the circuit board by sliding the connector onto the terminals. Make certain that the connector is fully seated on the terminals.
4. Slide the channel card into the connector in the unit. Make sure the card is fully seated.
5. Install the retainer screw to secure the channel card heat sink to the main heat sink.
6. Check the position of the channel card. Be sure to close the front cover before operating the unit.

7.3 Replacing an MCB

When replacing an MCB, do the following:

1. Remove mains power by shutting off the unit at the main isolation switch.
2. Open the front cover.
3. Loosen the 2 screws that hold the MCB on the bus bar and disconnect the load wiring.
4. Carefully pull the DIN rail retainer clip away from the body of the MCB with a flat screwdriver blade.
5. Rock the MCB loose from the DIN rail and bus bar.
6. Remove the old part and install a new MCB of the correct rating.
7. Be sure that the new circuit breaker is properly fastened to the DIN rail and bus bar. Connect the load wiring.
8. Check that all connections are tight.
9. Attach the cover panel earth wire and close the cover before powering on the unit.

8.0 C-Bus Programming

The C-Bus Professional Series Dimmer must be programmed before it will function as part of a C-Bus network. This can be accomplished using Learn Mode. However, using the C-Bus Toolkit software provides a greater level of flexibility and customisation. The software can be downloaded from the Clipsal Integrated Systems web site (www.clipsal.com/cis). Further information about programming C-Bus units is provided at this site.

C-Bus Toolkit software helps you to configure all operating parameters, including the setting of control sources and power-up options. Indicators and dimmers function only when mains are connected.

8.1 Network Burden

C-Bus Professional Series Dimmers incorporate a software selectable network burden. The network burden can be enabled from the unit's 'Global' tab in the C-Bus Toolkit software, but only if the C-Bus system clock is enabled, and the Unit Address is set to 001.

One network burden is normally required to ensure correct operation of each C-Bus network. The Network window of a C-Bus Toolkit project provides a summary of a C-Bus network according to the units added to the Database. This can be helpful in determining whether or not a burden is required on a particular network.

8.2 Network Clock

C-Bus Professional Series Dimmers incorporate a software selectable C-Bus system clock. The system clock is used to synchronise data communication over a C-Bus network. At least one active C-Bus system clock is required on each C-Bus network for successful communication. No more than three units on a C-Bus network should have their clock enabled, so this option is normally disabled using the C-Bus Toolkit software.

If a system clock is required, it can be enabled from the unit's 'Global' tab in the C-Bus Toolkit software.

9.0 Troubleshooting

At installation, before calling technical support, please check your unit for obvious problems.

- Isolate the problem, as much as possible, to a single circuit or function.
- Disconnect mains power at the panel. Check for loose input or load wiring.
- Recheck all wiring connections. Check for correct wiring of the C-Bus cables and connectors.
- Decode any channel indicator messages. A label with mode and status information is located inside the front cover.
- Make sure that any local or remote overrides are turned off.
- Verify C-Bus operating requirements such as voltage, clock and burden.
- Refer to the Toolkit online HELP for assistance.
- Further debugging of possible network problems can be achieved using the Clipsal C-Bus Network Analyser tool (5100NA).

10.0 Definitions and Acronyms

C-Bus network

The programmable logic control system for the dimmer unit.

MCB

Miniature circuit breaker

Megger® testing

A device applies a DC voltage (typically 600 to 2500 volts) for several minutes. While the voltage is applied, the device measures the current 'leaking' through the insulation and displays the resistance in Megohms.

RCCB

Residual current circuit breaker

RCD

Residual current device

RJ45

A connector type commonly used in network cabling and telephony applications. Typically, four twisted pairs are used.

toroidal choke

An inductive component constructed around a ring-shaped core.

11.0 Electrical Specifications

12-Channel Models:

**L5112D20LP / L5112D16LP / L5112D10LP
L5112D10TP**

Parameter	Description		
Model number	L5112D20LP	L5112D16LP	L5112D10LP L5112D10TP
AC supply voltage	415V AC	415V AC	415V AC
AC supply frequency	47-53 Hz	47-53 Hz	47-53 Hz
Number of Input phases	3	3	3
Warm up time	5 sec	5 sec	5 sec
Max load per phase	60 A	60 A	40 A
Maximum load RMS current per channel	20 A	16 A	10 A
Minimum load per channel	20 W for incandescents	20 W for incandescents	20 W for incandescents
Compatible Loads	Incandescent, 240V Halogen, Electronic transformer, Neon with iron-core transformer and Low-voltage lighting with electronic transformer, iron-core transformer or motor speed control		
Soft-start ramp up time	0.5 sec	0.5 sec	0.5 sec
Load current risetime	200μ sec	200μ sec	200μ sec
Power control range	1.5 % to 95 %	1.5 % to 95 %	1.5 % to 95 %
Standby AC supply current	See Note	See Note	See Note
Load terminal Standby leakage current	< 10 mA	< 10 mA	< 10 mA LE < 1 mA TE
Short circuit withstand strength	6kA	6kA	6kA
Rated insulation voltage	500 V	500 V	500 V
Dialectric test voltage	2500 V	2500 V	2500 V

Note: The standby current for the basic unit is 90mA; add 75mA for each LE channel and 15mA for each TE channel.

12-Channel Models:**L5112D5LP / L5112D3LP****L5112D5TP / L5112D3TP**

Parameter	Description	
Model number	L5112D5LP L5112D5TP	L5112D3LP L5112D3TP
AC supply voltage	415V AC	240V AC
AC supply frequency	47-53 Hz	47-53 Hz
Number of Input phases	3	1 or 2
Warm up time	5 sec	5 sec
Max load per phase	20 A	36 A (1) 18 A (2)
Maximum load RMS current per channel	5 A	3 A
Minimum load per channel	20 W for incandescents	20 W for incandescents
Compatible Loads	Incandescent, 240V Halogen, Electronic transformer, Neon with iron-core transformer and Low-voltage lighting with electronic transformer, iron-core transformer or motor speed control	
Soft-start ramp up time	0.5 sec	0.5 sec
Load current risetime	200 μ sec	200 μ sec
Power control range	1.5 % to 95 %	1.5 % to 95 %
Standby AC supply current	See Note 1	See Note 1
Load terminal Standby leakage current	< 10 mA LE < 1 mA TE	< 10 mA LE < 1 mA TE
Short circuit withstand strength	6kA	See Note 2
Rated insulation voltage Dialectric test voltage	500 V 2500 V	500 V 2500 V

Note 1: The standby current for the basic unit is 90mA; add 75mA for each LE channel and 15mA for each TE channel.

Note 2: The installer must connect the dimmer to mains with protection rated at 20A per input phase with 6kA short circuit withstand strength.

6-Channel Models:**L5106D20LP / L5106D10LP****L5106D20TP / L5106D16TP / L5106D10TP**

Parameter	Description		
Model number	L5106D20LP L5106D20TP	L5106D16TP	L5106D10LP L5106D10TP
AC supply voltage	415V AC	415V AC	415V AC
AC supply frequency	47-53 Hz	47-53 Hz	47-53 Hz
Number of Input phases	3	3	3
Warm up time	5 sec	5 sec	5 sec
Max load per phase	40 A	40A	20 A
Maximum load RMS current per channel	20 A	16A	10 A
Minimum load per channel	20 W for incandescents	20 W for incandescents	20 W for incandescents
Compatible Loads	Incandescent, 240V Halogen, Electronic transformer, Neon with iron-core transformer and Low-voltage lighting with electronic transformer, iron-core transformer or motor speed control		
Soft-start ramp up delay	0.5 sec	0.5 sec	0.5 sec
Load current risetime	200 μ sec	200 μ sec	200 μ sec
Power control range	1.5 % to 95 %	1.5 % to 95 %	1.5 % to 95 %
Standby AC supply current	See Note	See Note	See Note
Load terminal Standby leakage current	< 10 mA LE < 1 mA TE	< 1 mA	< 10 mA LE < 1 mA TE
Short circuit withstand strength	6kA	6kA	6kA
Rated insulation voltage	500 V	500 V	500 V
Dialectric test voltage	2500 V	2500 V	2500 V

Note : The standby current for the basic unit is 90mA; add 75mA for each LE channel and 15mA for each TE channel.

6-Channel Models:**L5 106D5LP / L5 106D3LP****L5 106D5TP / L5 106D3TP**

Parameter	Description	
Model number	L5106D5LP L5106D5TP	L5106D3LP L5106D3TP
AC supply voltage	415V AC	240V AC
AC supply frequency	47-53 Hz	47-53 Hz
Number of Input phases	3	1
Warm up time	5 sec	5 sec
Max load per phase	30 A	20 A
Maximum load RMS current per channel	5 A	3 A
Minimum load per channel	20 W for incandescents	20 W for incandescents
Compatible Loads	Incandescent, 240V Halogen, Electronic transformer, Neon with iron-core transformer and Low-voltage lighting with electronic transformer, iron-core transformer or motor speed control	
Soft-start ramp up time	0.5 sec	0.5 sec
Load current risetime	200 μ sec	200 μ sec
Power control range	1.5 % to 95 %	1.5 % to 95 %
Standby AC supply current	See Note 1	See Note 1
Load terminal Standby leakage current	< 10 mA LE < 1 mA TE	< 10 mA LE < 1 mA TE
Short circuit withstand strength	6kA	See Note 2
Rated insulation voltage Dielectric test voltage	500 V 2500 V	500 V 2500 V

Note 1: The standby current for the basic unit is 90mA; add 75mA for each LE channel and 15mA for each TE channel.

Note 2: The installer must connect the dimmer to mains with protection rated at 20A with 6kA short circuit withstand strength.

3-Channel Models:

L5103D20LP / L5103D10LP / L5103D5LP

L5103D20TP / L5103D10TP / L5103D5TP

Parameter	Description		
Model number	L5103D20LP L5103D20TP	L5103D10LP L5103D10TP	L5103D5LP L5103D5TP
AC supply voltage	415V AC	415V AC	240V AC
AC supply frequency	47-53 Hz	47-53 Hz	47-53 Hz
Number of Input phases	3	3	1
Warm up time	5 sec	5 sec	5 sec
Max load per phase	20 A	30 A 1 phase 10 A 3 phase	15 A
Maximum load RMS current per channel	20 A	10 A	5 A
Minimum load per channel	20 W for incandescents	20 W for incandescents	20 W for incandescents
Compatible Loads	Incandescent, 240V Halogen, Electronic transformer, Neon with iron-core transformer and low-voltage lighting with electronic transformer, iron-core transformer or motor speed control		
Soft-start ramp up time	0.5 sec	0.5 sec	0.5 sec
Load current risetime	200µ sec	200µ sec	200µ sec
Power control range	1.5 % to 95 %	1.5 % to 95 %	1.5 % to 95 %
Standby AC supply current	See Note	See Note	See Note
Load terminal Standby leakage current	< 10 mA LE < 1 mA TE	< 10 mA LE < 1 mA TE	< 10 mA LE < 1 mA TE
Short circuit withstand strength	6kA	6kA	6kA
Rated insulation voltage	500 V	500 V	500 V
Dielectric test voltage	2500 v	2500 V	2500 V

Note : The standby current for the basic unit is 90mA; add 75mA for each LE channel and 15mA for each TE channel.

12.0 Environmental and Mechanical Specifications

12.1 Environmental Specifications (all models)

Parameter	Description
EMC Environment	Environment A Environment 1 (see Note 1)
IP Rating	2XB (see Note 2)
Operating ambient temperature	0–45 degrees C (32–113 degrees F)
Minimum space between units	vertical: 100 mm; horizontal: 100 mm
Operating relative humidity	10% to 90%, non-condensing
Mounting mode	wall
Mounting bracket hole size	10 mm diameter
Types of electrical connection (Suitable for copper or aluminium conductors)	FFD; as detailed below: Fixed supply terminal for 1 x 25mm ² wire per phase Fixed load terminal for 1 x 6mm ² wire or 2 x 2.5mm ² wires Disconnectable aux (C-Bus) connectors for 3 x RJ45 2 x 4-pin female

Note 1: Environment A and Environment 1 mainly relate to low-voltage residential, commercial and light industrial locations and installations.

Note 2: To ensure compliance with IP rating 2XB, the installer must be sure that there is no opening greater than 10mm around either mains or lighting load cables entering the dimmer chassis. Refer to Wiring Instructions.

12.2 Leading Edge Mechanical Specifications

Model	Dimensions in mm (H x W x D)	Weight in Kg
L5112D20LP	713 x 455 x 164	40
L5112D16LP	713 x 455 x 164	40
L5112D10LP	713 x 412 x 164	31
L5112D5LP	713 x 405 x 115	26
L5112D3LP	602 x 405 x 115	23
L5106D20LP	451 x 455 x 164	27
L5106D10LP	451 x 412 x 164	21
L5106D5LP	451 x 405 x 115	18
L5106D3LP	358 x 405 x 115	16
L5103D20LP	289 x 455 x 164	15
L5103D10LP	289 x 412 x 164	12
L5103D5LP	289 x 405 x 115	10

12.3 Trailing Edge Mechanical Specifications

Model	Dimensions in mm (H x W x D)	Weight in Kg
L5112D10TP	713 x 455 x 164	25
L5112D5TP	713 x 412 x 164	24
L5112D3TP	713 x 412 x 164	23
L5106D20TP	713 x 455 x 164	18
L5106D16TP	713 x 455 x 164	18
L5106D10TP	451 x 455 x 164	20
L5106D5TP	451 x 412 x 164	18
L5106D3TP	451 x 412 x 164	17
L5103D20TP	451 x 455 x 164	15
L5103D10TP	289 x 455 x 164	10
L5103D5TP	289 x 412 x 164	10

13.0 Standards Complied

Declarations of Conformity

Australian/New Zealand EMC & Electrical Safety Frameworks and Standards



Professional Series Dimmer units comply with the following:

Regulation	Standard	Title
EMC	AS/NZS CISPR 14-1	Electromagnetic compatibility – Requirements for household appliances, electric tools and similar apparatus – Part 1: Emission
	AS/NZS CISPR 15	Limits and methods of measurement of radio disturbance characteristics of electrical lighting and similar equipment
Electrical Safety	AS/NZS 3439-1	Low-voltage switchgear and control gear assemblies. Part 1: Type-tested and partially type-tested assemblies
	IEC 60669-2-1	Switches for household and similar fixed electrical installations – Part 2: Particular requirements – section 1: Electronic switches

European Council Directives and Standards



Professional Series Dimmer units comply with the following:

Directive	Standard	Title
EMC Directive 2004/108/EC	EN 60669-2-1 Clause 26.1	Immunity to ESD, RFI, EFT, Surge Voltages, Voltage Dips and Interruptions
	EN 60669-2-1 Clause 26.2	RF and Low Frequency Emissions
	EN 55014-1 *	Electromagnetic compatibility – Requirements for household appliances, electric tools and similar apparatus - Emission
	EN 55015 *	Limits and methods of measurement of radio disturbance characteristics of electrical lighting and similar equipment
	EN 61000-3-2	Electromagnetic compatibility (EMC) – Part 3-2: Limits for harmonic current emissions (equipment input current up to and including 16A per phase)

Directive	Standard	Title
EMC Directive 2004/108/EC	EN 61000-3-3	Electromagnetic compatibility (EMC) – Part 3-3: Limits – Limitation of voltage changes, voltage fluctuations and flicker in public low-voltage systems, for equipment with rated current less or equal to 16A per phase and not subject to conditional connection
	EN 61000-3-5 *	Electromagnetic compatibility (EMC) – Part 3-5: Limits – Limitation of voltage fluctuations and flicker in low-voltage power supply systems for equipment with rated current greater than 16A
	EN 61000-3-11 *	Electromagnetic compatibility (EMC) – Part 3-11: Limits – Limitation of Voltage Changes, Voltage Fluctuations and Flicker in Public Low-voltage Supply Systems, for equipment with rated current less than 75A subject to conditional connection
Low Voltage Directive 2006/95/EC	EN 60439-1	Low-voltage switchgear and control gear assemblies. Part 1: Type-tested and partially type-tested assemblies
	EN 60669-2-1	Switches for household and similar fixed electrical installations – Part 2: Particular requirements – section 1: Electronic switches
RoHS Directive 2002/95/EC		Restriction of Hazardous Substances

* Applies to 16A and 20A units.

Additional Standards

Professional Series Dimmer units comply with the following:

Regulation	Standard	Title
Electrical Safety	IEC 60439-1	Low-voltage switchgear and control gear assemblies. Part 1: Type-tested and partially type-tested assemblies
	IEC 60669-2-1	Switches for household and similar fixed electrical installations – Part 2: Particular requirements – section 1: Electronic switches

14.0 Two-Year Warranty

The Professional Series Dimmers carry a two-year warranty against manufacturing defects.

Warranty Statement

- 1) The benefits conferred herein are in addition to, and in no way shall be deemed to derogate; either expressly or by implication, any or all other rights and remedies in respect to Clipsal Integrated Systems Product, which the consumer has under the Commonwealth Trade Practices Act or any other similar State or Territory Laws.
- 2) The warrantor is Clipsal Australia Pty Ltd. With registered offices in all Australian States.
- 3) This Clipsal Integrated Systems Product is guaranteed against faulty workmanship and materials for a period of two (2) years from the date of installation.
- 4) Clipsal Australia Pty Ltd reserves the right, at its discretion, to either repair free of parts and labour charges, replace or offer refund in respect to any article found to be faulty due to materials, parts or workmanship.
- 5) This warranty is expressly subject to the Clipsal Integrated Systems Product being installed, wired, tested, operated and used in accordance with the manufacturer's instructions.
- 6) All costs of a claim shall be met by Clipsal Australia Pty Ltd, however should the product that is the subject of the claim be found to be in good working order, all such costs shall be met by the claimant.
- 7) When making a claim, the consumer shall forward the Clipsal Integrated Systems Product to the nearest office of Clipsal Australia Pty Ltd with adequate particulars of the defect within 28 days of the fault occurring. The product should be returned securely packed, complete with details of the date and place of purchase, description of load, and circumstances of malfunction.

For all warranty enquiries, contact your local Clipsal sales representative. The address and contact number of your nearest Clipsal Australia office can be found at <http://www.clipsal.com/locations> or by telephoning Technical Support.

Notes

This page was left blank for formatting purposes.

Technical Support and Troubleshooting

For further assistance in using this product, consult your nearest Clipsal Integrated Systems (CIS) Sales Representative or Technical Support Officer.

Technical Support Contact Numbers	
Australia	1300 722 247 (CIS Technical Support Hotline)
New Zealand	0800 888 219 (CIS Technical Support Hotline)
Northern Asia	+852 2484 4157 (Clipsal Hong Kong)
South Africa	011 314 5200 (C-Bus Technical Support)
Southern Asia	+603 7665 3555 Ext. 236 or 242 (CIS Malaysia)
United Kingdom	0870 608 8 608 (Schneider Electric Support)

Technical Support Email: techsupport.cis@clipsal.com.au

Sales Support Email: sales.cis@clipsal.com.au

Product of Clipsal Australia Pty Ltd

A member of Schneider Electric
Telephone (08) 8269 0511
Facsimile (08) 8340 1724
Contact us clipsal.com/feedback

National Customer Service Enquiries:

Tel 1300 2025 25

Fax 1300 2025 56

clipsal.com

Clipsal Australia Pty Ltd reserves the right to change specifications, modify designs and discontinue items without incurring obligation and whilst every effort is made to ensure that descriptions, specifications and other information in this catalogue are correct, no warranty is given in respect thereof and the company shall not be liable for any error therein.

© Clipsal Australia Pty Ltd.

The identified trademarks and copyrights are the property of Clipsal Australia Pty Ltd unless otherwise noted.